

Autonics

Full Metal Long Sensing Distance Proximity Sensor PRFD SERIES

INSTRUCTION MANUAL



Thank you for choosing our Autonics product.
Please read the following safety considerations before use.

Safety Considerations

※Please observe all safety considerations for safe and proper product operation to avoid hazards.
※⚠ symbol represents caution due to special circumstances in which hazards may occur.

Warning Failure to follow these instructions may result in serious injury or death.

Caution Failure to follow these instructions may result in personal injury or product damage.

Warning

- Fail-safe device must be installed when using the unit with machinery that may cause serious injury or substantial economic loss. (e.g. nuclear power control, medical equipment, ships, vehicles, railways, aircraft, combustion apparatus, safety equipment, crime/disaster prevention devices, etc.) Failure to follow this instruction may result in personal injury, fire or economic loss.
- Do not use the unit in the place where flammable/explosive/corrosive gas, high humidity, direct sunlight, radiant heat, vibration, impact, or salinity may be present. Failure to follow this instruction may result in explosion or fire.
- Do not disassemble or modify the unit. Failure to follow this instruction may result in fire.
- Do not connect, repair, or inspect the unit while connected to a power source. Failure to follow this instruction may result in fire.
- Check 'Connections' before wiring. Failure to follow this instruction may result in fire.

Caution

- Use the unit within the rated specifications. Failure to follow this instruction may result in fire or product damage.
- Use dry cloth to clean the unit, and do not use water or organic solvent. Failure to follow this instruction may result in fire.
- Do not supply power without load. Failure to follow this instruction may result in fire or product damage.

Ordering Information

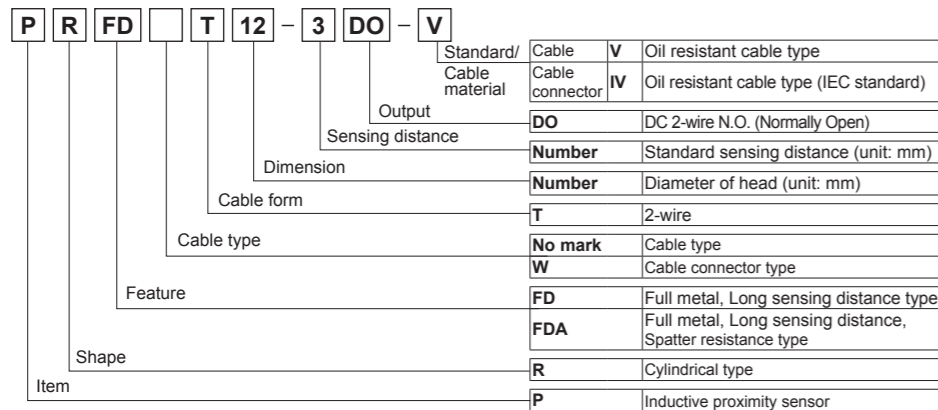

Control Output Diagram & Load Operating

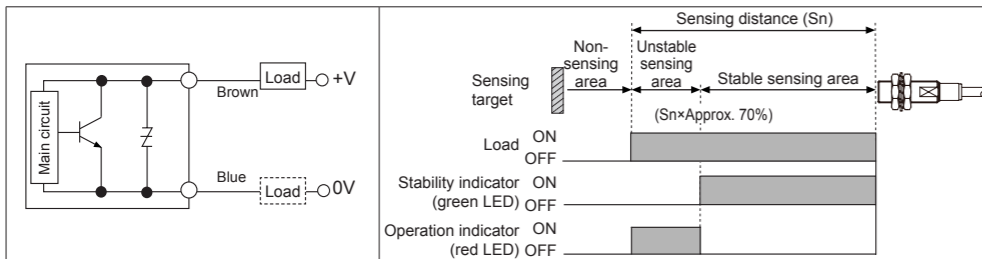

※The above specifications are subject to change and some models may be discontinued without notice.
※Be sure to follow cautions written in the instruction manual and the technical descriptions (catalog, homepage).

Specifications

Model	Cable type	PRFD08-2DO-V PRFDAT08-2DO-V	PRFD12-3DO-V PRFDAT12-3DO-V	PRFD18-7DO-V PRFDAT18-7DO-V	PRFD30-12DO-V PRFDAT30-12DO-V
	Cable connector type	PRFDW08-2DO-IV PRFDW08-2DO-IV	PRFDW12-3DO-IV PRFDW12-3DO-IV	PRFDW18-7DO-IV PRFDW18-7DO-IV	PRFDW30-12DO-IV PRFDW30-12DO-IV
	Diameter of the sensing side	8mm	12mm	18mm	30mm
	Sensing distance ^{※1}	2mm	3mm	7mm	12mm
	Installation	Shield (flush)			
	Hysteresis	Max. 15% of sensing distance			
	Standard sensing target	12×12×1mm (iron)	12×12×1mm (iron)	30×30×1mm (iron)	54×54×1mm (iron)
	Setting distance	0 to 1.4mm	0 to 2.1mm	0 to 4.9mm	0 to 8.4mm
	Power supply (operating voltage)	12-24VDC= (10-30VDC=)			
	Leakage current	Max. 0.8mA			
	Response frequency ^{※2}	150Hz	80Hz	80Hz	50Hz
	Residual voltage	Max. 3.5V			
	Affection by temperature	Max. ±20% for sensing distance at ambient temperature 20°C			
	Control output	Max. 3 to 100mA			
	Insulation resistance	Over 50MΩ (at 500VDC megger)			
	Dielectric strength	1,000VAC 50/60Hz for 1 min			
	Vibration	1.5mm amplitude at frequency 10 to 55Hz (for 1 min) in each X, Y, Z direction for 2 hours			
	Shock	500m/s ² (approx. 50G) in each X, Y, Z direction for 10 times	1,000m/s ² (approx. 100G) in each X, Y, Z direction for 10 times		
	Indicator	Stability indicator: green LED, Operation indicator: red LED			
	Environ Ambient temperature	-25 to 70°C, storage: -25 to 70°C			
	Ambient humidity	35 to 95%RH, storage: 35 to 95%RH			
	Protection circuit	Surge protection circuit, output short over current protection circuit			
	Protection	IP67 (IEC standard)			
	Cable	Cable type ^{※3} Ø4mm, 2-wire, 2m ^{※4} (AWG22, core diameter: 0.08mm, no. of cores: 60, insulator diameter: Ø1.25mm)	Ø5mm, 2-wire, 2m ^{※4} (AWG22, core diameter: 0.08mm, no. of cores: 60, insulator diameter: Ø1.25mm)		
	Cable connector type	Ø4mm, 2-wire, 300mm, M12 connector (AWG22, core diameter: 0.08mm, no. of cores: 60, insulator diameter: Ø1.25mm)	Ø5mm, 2-wire, 300mm, M12 connector (AWG22, core diameter: 0.08mm, no. of cores: 60, insulator diameter: Ø1.25mm)		
	Material	Case/Nut: stainless steel 303 (SUS303, PTFE coated ^{※5}), washer: stainless steel 304 (SUS304), sensing side: stainless steel 303 (SUS303, PTFE coated ^{※5} , thickness of PRFD(A)_T08: 0.2mm, PRFD(A)_T12/18: 0.4mm, PRFD(A)_T30: 0.5mm), oil resistant cable (gray): oil resistant polyvinyl chloride (PVC)			
	Approval	CE			
	Weight ^{※6}	Approx. 80g (approx. 55g)	Approx. 110g (approx. 83g)	Approx. 132g (approx. 97g)	Approx. 225g (approx. 170g)

※1: Use accessories (nut, washer) made of SUS. Or, sensing distance cannot be guaranteed.
※2: The response frequency is the average value. The standard sensing target is used and the width is set as 2 times of the standard sensing target, 1/2 of the sensing distance for the distance.
※3: Do not pull the Ø4mm cable with a tensile strength of 30N or over and the Ø5mm cable with a tensile strength of 50N or over. It may result in fire due to the broken wire. When extending wire, use AWG22 cable or over within 200m.
※4: Option is 5m.
※5: PTFE coated is only for spatter resistance type model.
※6: The weight includes packaging. The weight in parenthesis is for unit only.
※Environment resistance is rated at no freezing or condensation.

Dimensions

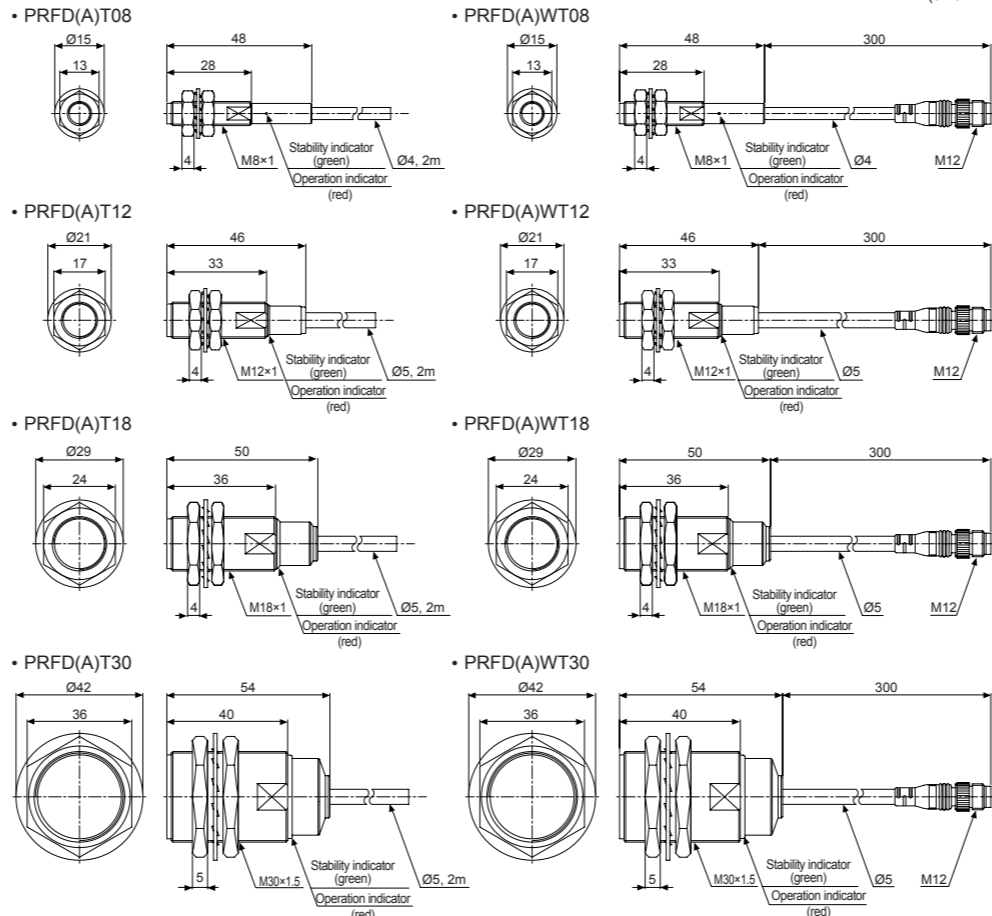

Connections

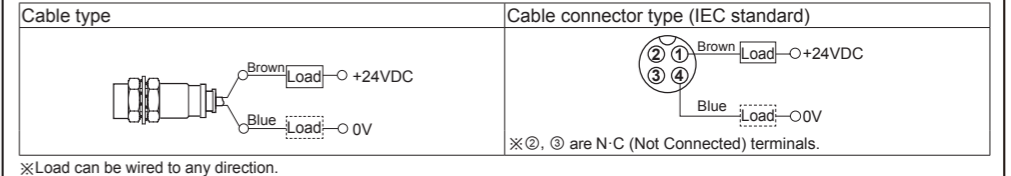

Mutual-Interference & Influence by Surrounding Metals

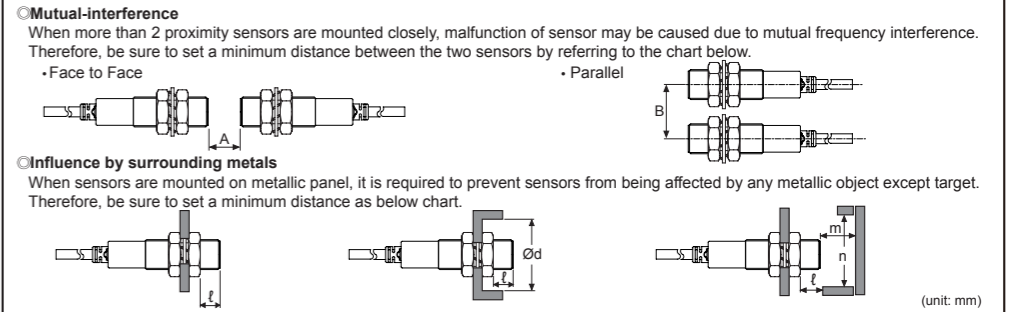

Item	Model	PRFD(A)_T08-2DO-□	PRFD(A)_T12-3DO-□	PRFD(A)_T18-7DO-□	PRFD(A)_T30-12DO-□
A		35	40	65	110
B		35	35	60	100
ℓ		0	0	0	0
Ød		8	12	18	30
m		8	12	28	48
n		30	40	60	100

Setting Distance

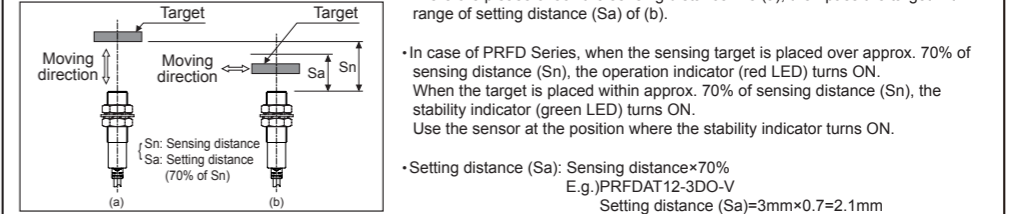

Effect of Aluminum Scraps

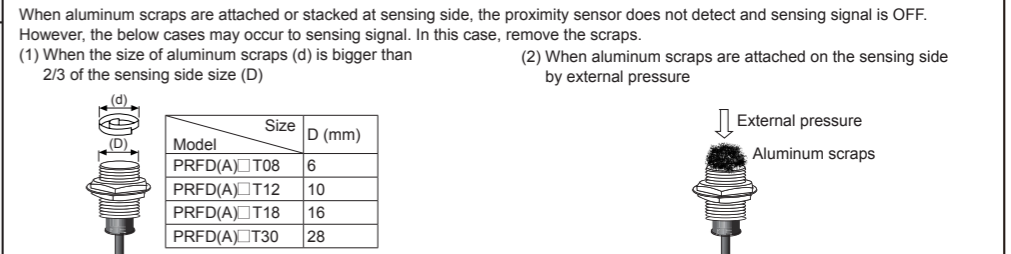

Installation and Tightening Torque

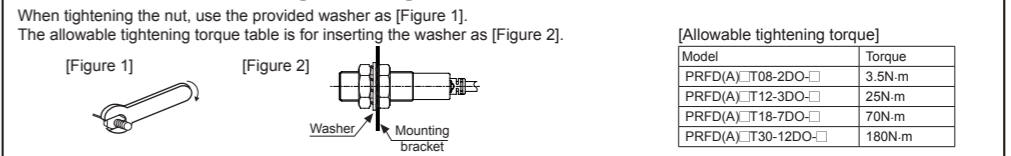

Cautions during Use

- Follow instructions in 'Cautions during Use'. Otherwise, it may cause unexpected accidents.
- 12-24VDC power supply should be insulated and limited voltage/current or Class 2, SELV power supply device.
- Use the product, after 0.5 sec of supplying power.
- Wire as short as possible and keep away from high voltage lines or power lines, to prevent surge and inductive noise. Do not use near the equipment which generates strong magnetic force or high frequency noise (transceiver, etc.). In case installing the product near the equipment which generates strong surge (motor, welding machine, etc.), use diode or varistor to remove surge.
- Do NOT connect the sensors more than three in parallel.
- If the surface of the product is rubbed with a hard object, PTFE coating can be worn out. This unit may be used in the following environments.
 - ① Indoors (in the environment condition rated in 'Specifications')
 - ② Altitude max. 2,000m
 - ③ Pollution degree 2
 - ④ Installation category II

Major Products

- Photoelectric Sensors
- Fiber Optic Sensors
- Door Sensors
- Door Side Sensors
- Area Sensors
- Proximity Sensors
- Pressure Sensors
- Rotary Encoders
- Connector/Sockets
- Temperature Controllers
- Temperature/Humidity Transducers
- SSRs/Power Controllers
- Counters
- Timers
- Panel Meters
- Tachometers/Pulse (Rate) Meters
- Display Units
- Sensor Controllers
- Switching Mode Power Supplies
- Control Switches/Lamps/Buzzers
- I/O Terminal Blocks & Cables
- Stepper Motors/Drivers/Motion Controllers
- Graphic/Logic Panels
- Field Network Devices
- Laser Marking System (Fiber, Co., Nd: YAG)
- Laser Welding/Cutting System

Autonics Corporation
http://www.autonics.com

HEADQUARTERS:
18, Bansong-ro 513beon-gil, Haeundae-gu, Busan, South Korea, 48002
TEL: 82-51-519-3232
E-mail: sales@autonics.com